

Datasheet

Wallbox 22kW 32A

Tree

Part No: 100677



About the product

The LOXONE Wallbox is a charging station that enables dynamic charging from 4.1kW to 22kW for electric vehicles. With the robust Tree Interface, the device is fully integrated into the LOXONE system, providing full flexibility for energy management.

- Cost-effective and extremely fast: AC-charging with 22 kW
- Easy installation thanks to the **integrated LOXONE Energy Meter 3-Phase Tree**
- Charge for free: use PV surplus efficiently
- Electricity exchange included: charge cheaply, even without a PV system. Ideal for variable electricity tariffs.
- Easy operation with the LOXONE App or by expanding with the Touch Pure Flex or NFC Code Touch
- User identification and billing via NFC
- Suitable for fleets: protection of wiring and building infrastructure thanks to optimal power distribution
- Up to 5 customizable charging modes
- OCPP capable
- MID-compliant meter, factory-installed
- Certified for TOR in accordance with OVE R37:2024

Electrical Specifications

Rated voltage	AC Input (mains)	24 VDC Input
	3 x 230/400 V, 50 Hz	18-24 V
Current	3 x 32 A	max. 120 mA
Power consumption	Standby: 0.4 W Charging: 3 W	Standby: 0.3 W Charging: 1.8 W
Total power loss	6.9 W (while charging with 32 A / phase inside the wallbox)	-

A 30 mA type A RCD must be connected before each wallbox!

Energy Meter 3-Phase Tree (100567)

Measurement accuracy	MID / Class B EN 50470 / Class 1 IEC 62053 / Class 0.5 ANSI C12.1
----------------------	---

Charging

Max. charging power	22 kW (3 phase 32 A) configurable from 4.1 kW to 22 kW
---------------------	--

Charging Mode	Charging mode 3 (IEC 61851-1)
---------------	-------------------------------

Residual current detection	Internal, RDC-MD, DC 6 mA, (IEC 62955)
----------------------------	--

Charging cable with plug	Type 2 plug (IEC 62196) 5 meter cable, 5 x 4 mm ² + 1 x 0.5 mm ²
--------------------------	---

Interfaces

LOXONE Tree	Connection with Miniserver / Tree Extension
-------------	---

Modbus RTU	max. 1 device max. 3 m wire length adjustable baud rate & parity data types: 16 & 32 bit min. polling cycle: 0.1 s / 1 s
------------	--

OCPP	1.6 & 2.0.1, NFC Code Touch required
------	--------------------------------------

Ambient Conditions

Temperature	-20 ... 50 °C / -4 ... 122 °F
-------------	-------------------------------

Humidity	max. 95 % RH (non-condensing)
----------	-------------------------------

Ingress protection	IP44 (IEC 60529) IK08 (IEC 62262)
--------------------	--------------------------------------

Appliance class	Class I
-----------------	---------

Installation	Stationary, surface mount, vertical on wall or charging post
--------------	--

Recommended mounting height	Cable outlet: 132 cm Top edge: 165 cm
-----------------------------	--

Altitude	max. 2000 m
----------	-------------

Connection Terminals

Terminal type	AC Input - PE	AC Input - L1, L2, L3, N	DC Input, LOXONE Tree	Modbus
	WPE6	-	A3C 1.5	SPTAF1
Wire cross-section	0.5 ... 10 mm ²	1.5 ... 25 mm ²	0.14 ... 1.5 mm ²	0.25 ... 0.75 mm ²
	ferrules required for fine-stranded conductors			
Stripping length	12 mm	14 ... 15 mm	8 mm	8 mm
Temperature resistance	-40 ... 105 °C	-40 ... 70 °C	-60 ... 130 °C	-60 ... 100 °C
Tightening torque	1.3 Nm	3 Nm	(Push-In)	
Screw drive	0.8 x 4 mm	PZ2	(Push-In)	

Connection Diagram

Connection Diagram

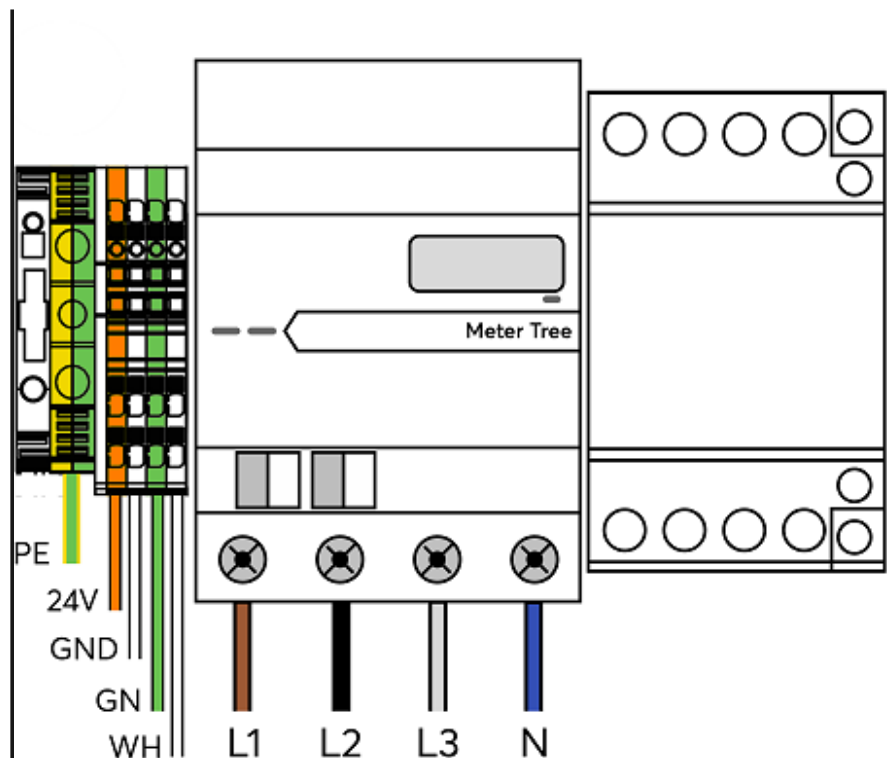

Product Characteristics

Colours	Housing: RAL 9005 Decor cover: RAL 9003
Finish	Matte



Weight & Dimensions

Net weight	4.4 kg
Total weight	5.9 kg
Product dimensions	430 x 190 x 130 mm (H x W x D)

Product dimensions drawing	
----------------------------	--

Pack size	575 x 395 x 155 mm (H x W x D)
-----------	--------------------------------

Certifications & Standards

Degree of pollution	3
Standards	CE (LVD 2014/35/EU, EMC 2014/0/EU) IEC 61851-1 IEC 61851-22
Certifications	Compatible with ChargePoint be.ENERGISED (OCPP 1.6)
Certifications	 

Installation must be carried out by a qualified electrician in accordance with the relevant regulations.

Published by

Loxone Electronics GmbH
Smart Home 1
4154 Kollerschlag
Austria
Tel: +43 7287 7070-0
loxone.com

Loxone UK Ltd.
The Forum
Station Road
Theale, RG7 4RA
United Kingdom

Datenblatt

Wallbox 22kW 32A

Tree

Part No: 100677



Über das Produkt

Die LOXONE Wallbox ist eine Ladestation, die **dynamisches Laden von 4,1kW bis 22kW für Elektrofahrzeuge** ermöglicht. Mit der robusten **Tree Schnittstelle** wird das Gerät in das LOXONE-System integriert, und bietet alle Freiheiten für das **Energiemanagement**.

- Kostengünstig und maximal schnell: Laden mit 22kW Wechselstrom
- Einfache Installation dank **vorinstalliertem LOXONE Energiezähler 3-phasig Tree**
- Kostenlos laden: PV-Überschuss effizient nutzen
- Strombörse inklusive: Günstig laden, auch ohne PV-Anlage. Ideal für variable Stromtarife
- Einfache Bedienung mit der LOXONE App oder durch Erweiterung mit dem Touch Pure Flex bzw. NFC Code Touch
- Nutzeridentifikation und Abrechnung per NFC
- Flottentauglich: Absicherung der Leitung und des Gebäudes dank optimaler Leistungsverteilung
- Bis zu 5 anpassbare Lademodi
- OCPP-fähig
- MID-konformer Zähler ab Werk
- Zertifiziert für TOR nach OVE R37:2024

Elektrische Spezifikationen

Nennspannung	AC-Eingang (Netzspannung)	24 VDC Eingang
	3 x 230/400 V, 50 Hz	18-24 V
Strom	3 x 32 A	max. 120 mA
Leistungsaufnahme	Standby: 0.4 W Laden: 3 W	Standby: 0.3 W Laden: 1.8 W
Gesamtverlustleistung	6,9 W (beim Laden mit 32 A / Phase in der Wallbox)	-

Jeder Wallbox muss ein 30mA Typ A Fehlerstrom-Schutzschalter (RCD) vorgeschaltet werden.

Energy Meter 3-Phase Tree (100567)

Messgenauigkeit	MID / Klasse B EN 50470 / Klasse 1 IEC 62053 / Klasse 0.5 ANSI C12.1
-----------------	--

Laden

Max. Ladeleistung	22 kW (3 phasig 32 A) einstellbar von 4,1 kW bis 22 kW
-------------------	--

Ladebetriebsart	Ladebetriebsart 3 (IEC 61851-1)
-----------------	---------------------------------

Fehlerstromerkennung	Intern, RDC-MD, DC 6 mA, (IEC 62955)
----------------------	--------------------------------------

Ladekabel mit Stecker	Typ 2 Stecker (IEC 62196) 5 Meter Kabel, 5 x 4 mm ² + 1 x 0,5 mm ²
-----------------------	---

Schnittstellen

LOXONE Tree	Verbindung mit Miniserver / Tree Extension
-------------	--

Modbus RTU	max. 1 Gerät max. 3 m Leitungslänge einstellbare Baudrate & Parität Datentypen: 16 & 32 bit min. Abfragezyklus: 0,1s / 1s
------------	---

OCPP	1.6 & 2.0.1, NFC Code Touch erforderlich
------	--

Umgebungsbedingungen

Temperatur	-20 ... 50 °C / -4 ... 122 °F
------------	-------------------------------

Luftfeuchtigkeit	max. 95 % r. F. (nicht kondensierend)
------------------	---------------------------------------

Schutzart	IP44 (IEC 60529) IK08 (IEC 62262)
-----------	--------------------------------------

Schutzklasse	Klasse I
--------------	----------

Installation	Ortsfest, Aufbaumontage, vertikal an Wand oder Ladesäule
--------------	--

Empfohlene Montagehöhe	Kabelauslass: 132 cm Oberkante: 165 cm
------------------------	---

Betriebshöhe	max. 2000 m
--------------	-------------

Anschlussklemmen

Klemmentyp	AC-Eingang - PE	AC-Eingang - L1, L2, L3, N	DC-Eingang, LOXONE Tree	Modbus
	WPE6	-	A3C 1.5	SPTAF1
Leiterquerschnitt	0,5 ... 10 mm ²	1,5 ... 25 mm ²	0,14 ... 1,5 mm ²	0,25 ... 0,75 mm ²
	Aderendhülsen erforderlich für feindrähtige Leiter			
Abisolierlänge	12 mm	14 ... 15 mm	8 mm	8 mm
Temperaturbeständigkeit	-40 ... 105 °C	-40 ... 70 °C	-60 ... 130 °C	-60 ... 100 °C
Anzugsdrehmoment	1,3 Nm	3 Nm	(Push-In)	
Schraubenantrieb	0,8 x 4 mm	PZ2	(Push-In)	

Anschlussplan

Anschlussplan

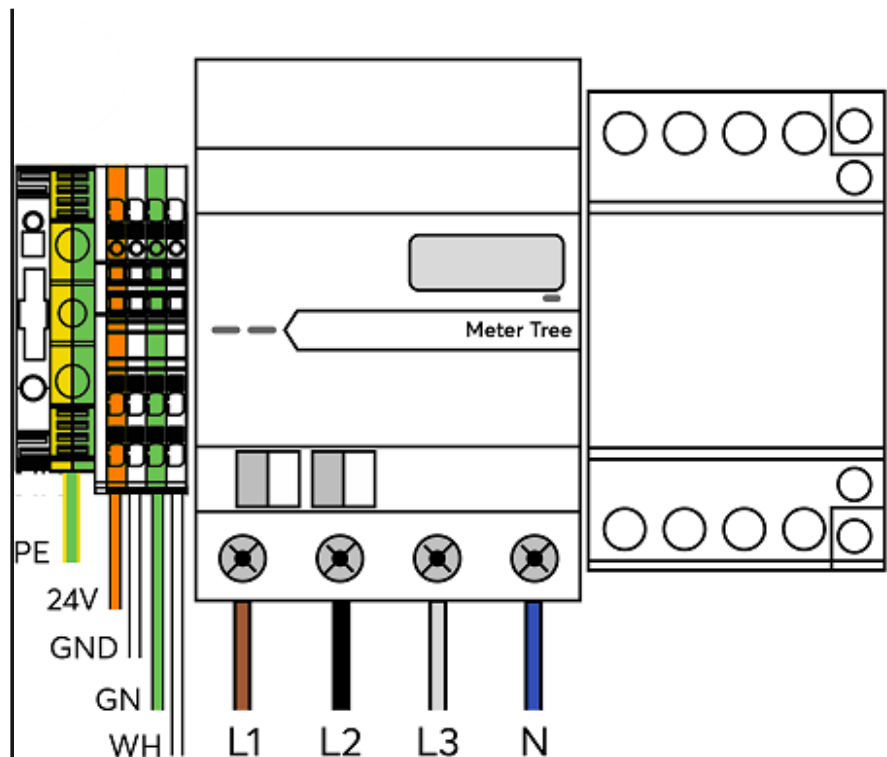

Produkteigenschaften

Farbe	Gehäuse: RAL 9005 Dekorabdeckung: RAL 9003
Glanzgrad	Matt

Gewicht & Abmessungen

Nettogewicht	4,4 kg
Bruttogewicht	5,9 kg
Produktmaße	430 x 190 x 130 mm (H x B x T)

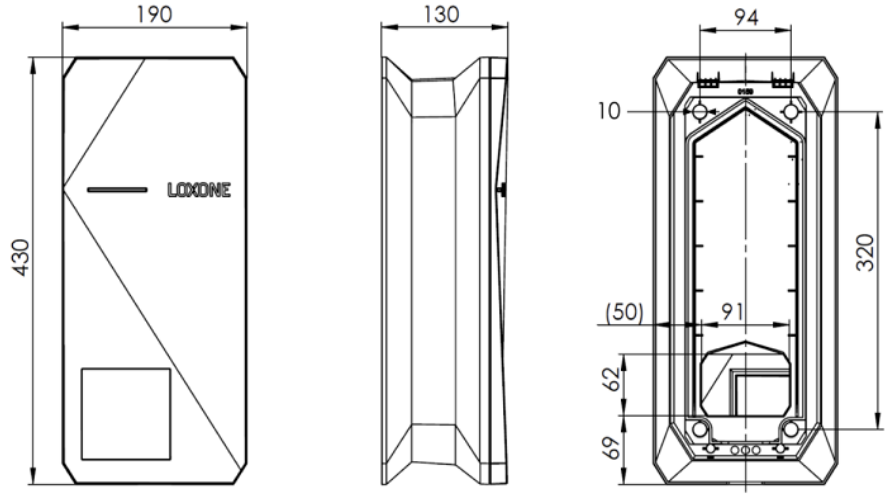
Produktmaßzeichnung	
---------------------	---

Packmaß	575 x 395 x 155 mm (H x B x T)
---------	--------------------------------

Zertifizierungen & Standards

Verschmutzungsgrad	3
Normen	CE (LVD 2014/35/EU, EMCD 2014/0/EU) IEC 61851-1 IEC 61851-22
Zertifizierungen	Kompatibel mit ChargePoint be.ENERGISED (OCPP 1.6)

Zertifizierungen	 
------------------	---

Die Installation muss von einer qualifizierten Elektrofachkraft gemäß den einschlägigen Vorschriften durchgeführt werden.

Veröffentlicht von

Loxone Electronics GmbH
Smart Home 1
4154 Kollerschlag
Austria
Tel: +43 7287 7070-0
loxone.com

Loxone UK Ltd.
The Forum
Station Road
Theale, RG7 4RA
United Kingdom